

## MONOLITHIC RING LASER GYRO (MRLG) INERTIAL NAVIGATION UNIT (INU)

**KI-4902**

**HIGH  
PERFORMANCE  
INU KIT  
w/compact CCA's**

Kearfott's KI-4902 INU is ideally suited for those applications requiring high performance in a compact form factor.

Cost, performance and size advantages have been achieved by incorporating the T24 MRLG and a MOD VIIA Accelerometer Triad into an Inertial Sensor Assembly (ISA), and developing the associated INU electronics to fit on a compact card assembly.

The MRLG shown above as three assemblies, is designed for incorporation into a users end item and thus eliminates the requirement for a separate Line Replaceable Unit. A serial data RS-422 port provides integrate DVL/GPS/INS navigation.

- ALL NAVIGATION COMPUTATIONS
  - At Sea Moving align capable w/GPS aiding
  - Continuous "Align-On-The-Move"
  - Vehicle Dynamic Control
- MULTIPLE I/O PORTS
- INTERFACES WITH:
  - GPS
  - Sonar/Doppler
- SIMPLIFIED ELECTRONICS
- HIGH RELIABILITY, LOW LIFE CYCLE COST



PERFORMANCE SUMMARY**		
PARAMETERS	GYRO	ACCELEROMETER
Random Walk	0.003°/√h	0.05 m/s/√h
Bias Repeatability	0.005°/h	100 μg
Scale Factor Repeatability	50 PPM	100 PPM
Axis Alignment	15 arc-second	20 arc-second
Bias Stability	0.003°/h	50 μg
Vibration Rectification	N/A	15 μg/g <sup>2</sup> typical

Note: All parameter values listed are 1σ

DYNAMIC CONDITIONS**	
Acceleration Range	40 g's *
Attitude	unlimited
Roll, Pitch and Azimuth Angular Rate	300°/s
Roll, Pitch and Azimuth Accelerations	10,000°/s <sup>2</sup>
Cooling	Free convection
Environmental Requirements	Per MIL-E-5400

PHYSICAL CHARACTERISTICS **	
Dimensions - ISA & IMU Electronics	ISA - 4.5" DIA. x 6.3" L, CCA's - 80 in <sup>2</sup>
Weight - ISA & IMU Electronics	8.5 lb (6.5 lb ISA, <2 lb CCA's/Heatsink)
Power	+15 V, -15 V, +5 V, and < 30 Watts
Activation Time	< 5 s
Maintenance	BIT, 95% coverage
Calibration Interval	None

\* Can be rescaled from 1 to 100g

\*\* Performance, Operating Ranges, and Characteristics are tailorable for specific applications

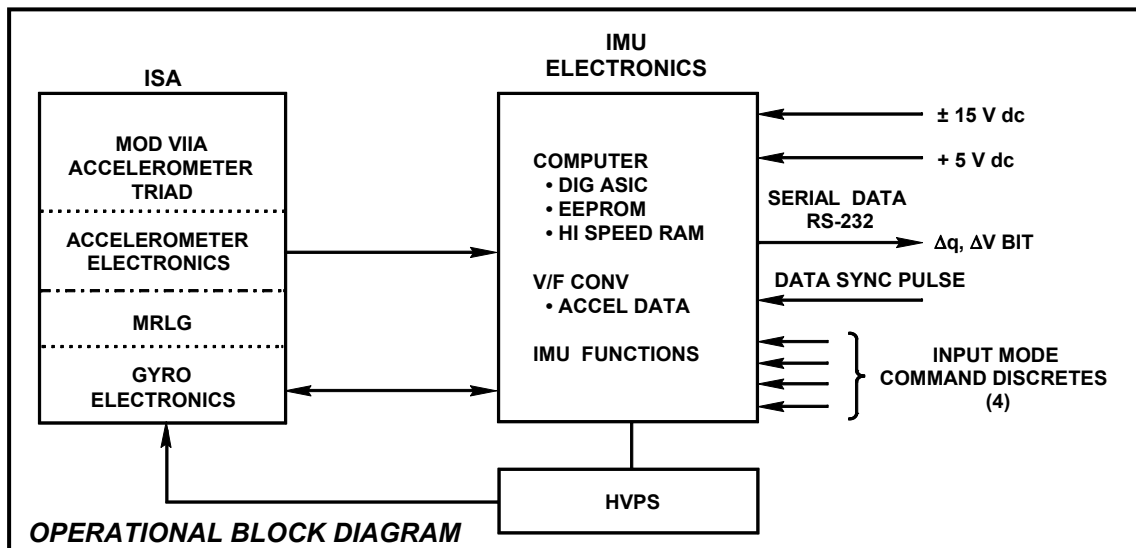

FOR FURTHER INFORMATION ON THIS HIGH PERFORMANCE APPLICATION,  
TACTICAL APPLICATION OR ANY OTHER PRODUCT APPLICATIONS,  
PLEASE CONTACT OUR BUSINESS DEVELOPMENT GROUP AT: (973) 785-6555 OR FAX (973) 785-5905  
Visit our website: [www.kearfott.com](http://www.kearfott.com)