

BRUSHLESS DC MOTOR CONTROLLER AND ROTARY ACTUATOR

The Kearfott Brushless DC Motor Controller (C703532012) is designed to drive the Kearfott Rotary Actuator (CU09660018). This system controls the fin actuators for the AQS-20 Towed Sonar Array. The controller for this application is a closed-loop design which follows a DC voltage level input command. The DC level represents the desired angle of the output shaft. The circuit includes compensation for controlling the system's stability. Position feedback from a potentiometer driven from the output shaft is used in the loop closure. This feedback signal is conditioned as required and passed back to the customer supplied interface. The brushless motor controller provides excitation for the Hall switching used in the brushless motor and the appropriate 3-phase drive currents for the motor windings. The drive currents are pulse width modulated for improved efficiency. Controller current is limited on a peak-by-peak basis. The controller features a brake circuit to stop movement of the actuator when power is turned off. This system uses +28 volts and ± 12 volts. The electronics will operate from -40°C to $+85^{\circ}\text{C}$.

ACTUATOR CHARACTERISTICS

Characteristics	Units	Symbol	Value
Ratio Motor to Ballnut	–	N	2.342:1
Ballscrew Lead	in	l	0.125
Crank Radius	in	–	1.5
No Load Speed (min)	$^{\circ}/\text{s}$	ω_{nl}	50
Restraint Torque	in-lb	T_P	800
Rated Torque (min)	in-lb	T_r	600
Rated Speed (min)	$^{\circ}/\text{s}$	ω_r	40

PERFORMANCE

Speed at 400 in/lb	$50^{\circ}/\text{s}$ (min) @ 3.0 amps (max)
Speed at 600 in/lb	$40^{\circ}/\text{s}$ (min) @ 4.5 amps (max)
Stall Torque	800 in-lb (min) @ 6.2 amps (max)
Electrical Stroke	$\pm 25.15^{\circ}$ (max)
Mechanical Stroke	$\pm 27.00^{\circ}$ (min)
Steady-State Position Error	$\pm 0.15^{\circ}$ (max)
Static Stiffness	400 in-lb/ $^{\circ}$ (min)
Weight (Actuator + Controller)	5.1 lb (max)

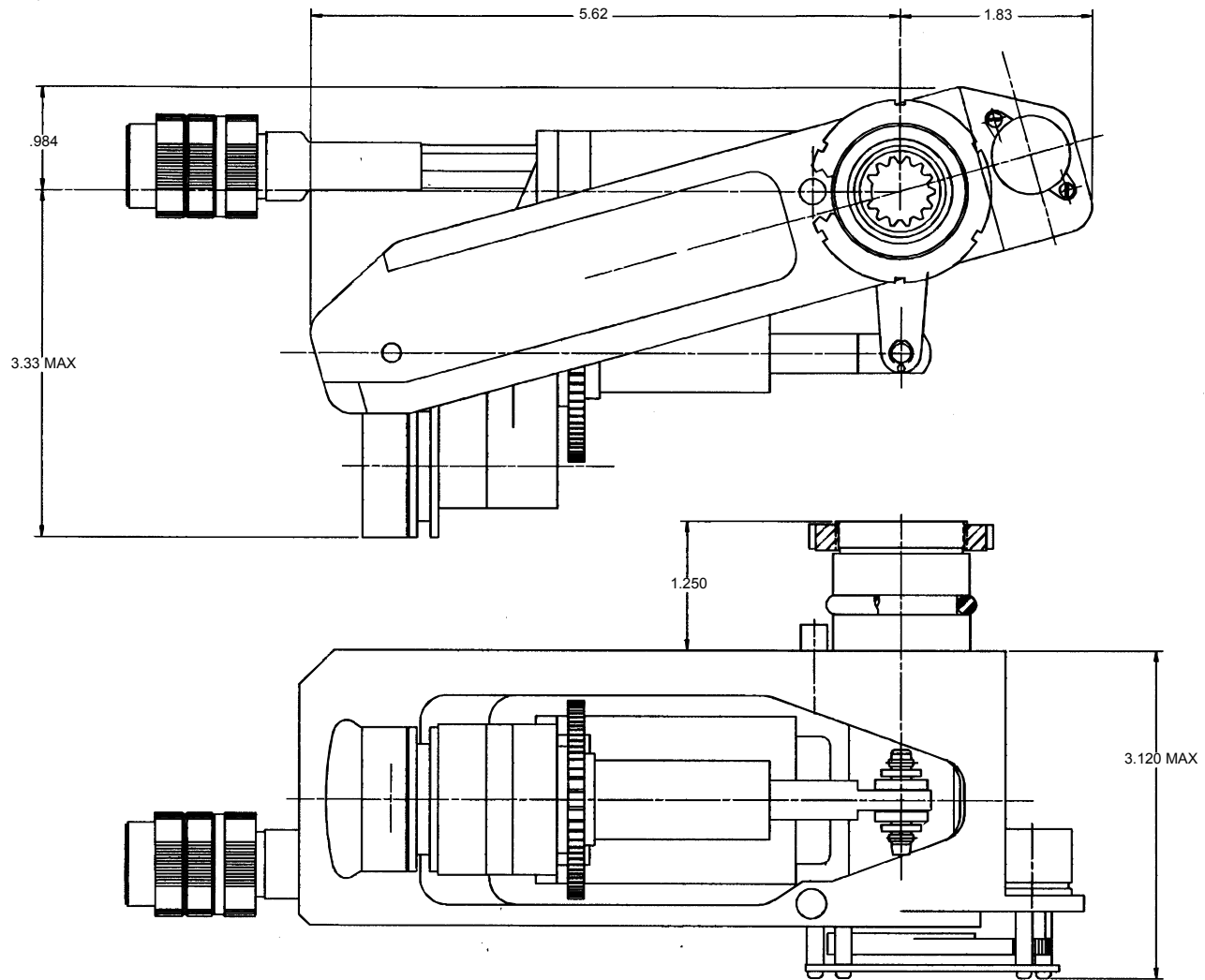

ASHEVILLE PRODUCT LIST

SENSORS

LVDT
RVDT
Synchros
Resolvers

ELECTRONICS

PWM Amps
Servo Amps
Converters
Power Supplies

MOTORS

AC
DC
Brush/Brushless
Induction/Synchronous

ACTUATORS

Linear
Rotary

OTHER

Motor Gearheads
Servo Systems
Dampers
Angle Sensors
Torquers
Tachometers
Generators
Alternators
PC Boards
Harnesses

For additional information on this product or any other product listed above please contact Kearfott's Marketing Department at:

Kearfott Corporation • Motion Systems Division

2858 Route 70 W, Black Mountain, North Carolina 28711-9111 USA • Telephone (828) 350-5300 • Fax (828) 686-5764

Website: www.kearfott.com